

Product Family Data Sheet Rev. 5.0 2025. 11.24

2835 Series

Far Red

For Horticulture Lighting
植物照明

Features & Benefits 特点与优势

- 1.0 W class middle power LED
1.0W级中功率LED
- Silicone resin for high reliability
高可靠性硅树脂封装
- Standard form factor for design flexibility (2.8 × 3.5 mm)
标准封装尺寸，设计更加灵活
- Wall-Plug Efficiency: Typ. 52.2% @ 150 mA, 25 °C
电-光转换效率典型值: 52.2% @ 150 mA, 25 °C

Application应用:



LED封装进口替代首选品牌
First Choice in LED Packaging Category

Table of Contents

目 录

1.	Characteristics 特征	-----	3
2.	Product Code Information 产品编码信息	-----	4
3.	Product Selection Guide 产品选型指南	-----	7
4.	Typical Characteristics Graphs 典型特性曲线	-----	8
5.	Outline Drawing & Dimension 外形尺寸图	-----	11
6.	Reliability Test Items & Conditions 可靠性测试项目及条件	-----	12
7.	Soldering Conditions 焊接条件	-----	13
8.	Tape & Reel 卷装	-----	14
9.	Label Structure 标签结构	-----	16
10.	Packing Structure 包装结构	-----	17
11.	Precautions in Handling & Use 使用注意事项	-----	19
12.	Document Revision History 文件修订记录	-----	20

1. Characteristics 特征

a) Absolute Maximum Rating 极限参数

Item 项目	Symbol 符号	Rating 额定值	Unit 单位	Condition 条件
Operating Solder Point Temperature 焊点工作温度	T_s	-40 ~ 105	°C	-
Storage Temperature 储存温度	T_{stg}	-40 ~ 105	°C	-
LED Junction Temperature LED结温	T_j	125	°C	-
Forward Current 正向电流	I_f	281M: 150 282M: 300	mA	-
Pulse Forward Current 脉冲正向电流	I_{FP}	281M: 300 282M: 600	mA	Duty 1/10, pulse width 10 ms 占空比1/10, 脉冲宽度10毫秒
Soldering Process Temperature 焊接过程温度	-	260 <10	°C s	-
ESD Withstand Voltage(HBM) 静电耐压 (人体模式)	-	2	kV	-

b) Electro-optical Characteristics 光电参数 ($I_f = 150 \text{ mA}$, $T_j = 25 \text{ °C}$)

Item 项目	Unit 单位	Rank 范围	Min. 最小值	Typ. 典型值	Max. 最大值
Forward Voltage(V_f) 正向电压	V	V0	1.8	-	2.4
Reverse Current(I_R @ $V_R=5V$) 反向电流	μA		-	-	1
Peak wavelength(WLP) 峰值波长	nm	NR0	720	-	740
Yield Photon Flux(350-750nm) 产生的光子通量(350-750nm)	μmol/s		0.80	-	1.20
Radiant Flux(Φ_e) 辐射通量	mW		140	-	180
Photosynthetic Active Radiation(PAR) 光合有效辐射	mW		140	-	180
Thermal Resistance 热阻	°C/W		-	20	-
Beam Angle 发光角度	°		-	120	-

Note 备注:

Ledestar maintains measurement tolerance of: forward voltage = $\pm 0.1 \text{ V}$, Radiant Flux = $\pm 5\%$, wavelength = $\pm 1 \text{ nm}$.
 立德达的测试公差保持在: 正向电压= $\pm 0.1\text{V}$, 波长= $\pm 1\text{nm}$, 辐射通量= $\pm 5\%$ 。

2. Product Code Information 产品编码信息

a) Model Code Information 型号编码信息

1	2	3	4	5	6	7	8	9	10	11	12	13	14	15	16	17	18	19	20	21		
L	D	R	-	2	8	3	5	L	T	A	F	7	3	0	-	V	0	N	R	0	H	0

Digit 数位	PKG Information 信息	Code 代码	Specification 规格
1 2 3	Ledstar Package 立德达封装	LDR	
4 5 6 7	Package Model and Size 封装型号尺寸	2835	2.8 x 3.5 x 1.85 mm
8	Product Category 产品类别	L	Top View&Lens 顶部发光&透镜
9	Lead Frame Type 支架类型	T	T: PCT & Cu
10	Bonding Wire 键合线	A	A: Au > 99.9% 纯金线 B: Ag > 80% 银线 C: 30% < Au < 80% 高金合金线
11 12	Color 发光颜色	F	Far red 远红光
12 13 14	Typ. Peak Wavelength 典型峰值波长	730	See the graded list for details 详见分光参数列表
15 16	Forward Voltage 正向电压	V0	See the graded list for details 详见分光参数列表
17 18 19	Wavelength Code 波长代码	NR0	See the graded list for details 详见分光参数列表
20 21	Radiant Flux 辐射通量	H0	See the graded list for details 详见分光参数列表

b) Series Code Information 系列编码信息

1	2		3		4
2	8		1		M

Digit 数位	PKG Information 信息	Code 代码	Specification 规格
1 2	Package Model 封装型号	28	2835
3	Number of Chips 芯片数量	1	1: 1 Chips 2: 2 Chips
4	Chip Size Level 芯片尺寸等级	M	M: 20 mil

c) Voltage Bins 电压分档 ($I_f = 150 \text{ mA}$, $T_j = 25 \text{ }^\circ\text{C}$)

Voltage Bin 电压分档	Voltage Range(V) 电压范围	Voltage Bin 电压分档	Voltage Range(V) 电压范围	Voltage Bin 电压分档	Voltage Range(V) 电压范围
A0	1.80 - 2.00	A1	1.80 - 1.90	A3	1.80 - 1.85
				A4	1.85 - 1.90
				A5	1.90 - 1.95
		A2	1.90 - 2.00	A6	1.95 - 2.00
				B3	2.00 - 2.05
				B4	2.05 - 2.10
B0	2.00 - 2.20	B1	2.00 - 2.10	B5	2.10 - 2.15
				B6	2.15 - 2.20
				C3	2.20 - 2.25
				C4	2.25 - 2.30
				C5	2.30 - 2.35
				C6	2.35 - 2.40
C0	2.20 - 2.40	C1	2.20 - 2.30		

Note 备注:

Ledestar defaults to a voltage level of 0.1 V for grading, The total range code is V0.

立德达默认分电压等级为0.1V分档，总范围代码为V0。

d) Peak Wavelength Bins ($I_f = 150 \text{ mA}$, $T_j = 25 \text{ }^\circ\text{C}$) 峰值波长分档

Peak Wavelength Bin 峰值波长分档	Peak Wavelength Range(nm) 峰值波长范围	Peak Wavelength Bin 峰值波长分档	Peak Wavelength Range(nm) 峰值波长范围	Color & Typ. Peak Wavelength 发光颜色与典型波长
NR0	720 - 740	NR1	720 - 725	F730
		NR2	725 - 730	
		NR3	730 - 735	
		NR4	735 - 740	

e) Radiant Flux Bins ($I_f = 150 \text{ mA}$, $T_j = 25 \text{ }^\circ\text{C}$) 辐射通量分档

Radiant Flux Rank 辐射通量分档	Radiant Flux Bin 辐射通量分档	Radiant Flux Range(mw) 辐射通量范围	Radiant Flux Bin 辐射通量分档	Radiant Flux Range(mw) 辐射通量范围
H0	HQ	140 - 150	QR	145 - 155
	HR	150 - 160		
	HS	160 - 180	RS	155 - 165

3. Product Selection Guide 产品选型指南

 Table 1. List of optional models for 281M series, $I_f = 150 \text{ mA}$, $T_j = 25 \text{ }^\circ\text{C}$

表1: 281M系列可选型列表

Series Code 系列代码	Model Code 型号代码	Peak Wavelength Typ.(nm) 典型峰值波长	Voltage Range(V) 电压范围	Radiant Flux Range(mw) 辐射通量范围	Peak Wavelength Range(nm) 峰值波长范围
281M	LDR-2835LT*F730-V0NR0H0	730	1.8 - 2.4V	140 - 180	720 - 740

 Table 2. List of optional models for 282M series, $I_f = 150 \text{ mA}$, $T_j = 25 \text{ }^\circ\text{C}$

表2: 282M系列可选型列表

Series Code 系列代码	Model Code 型号代码	Peak Wavelength Typ.(nm) 典型峰值波长	Voltage Range(V) 电压范围	Radiant Flux Range(mw) 辐射通量范围	Peak Wavelength Range(nm) 峰值波长范围
282M	LDR-2835LT*F730-V0NR0H0	730	1.8 - 2.4V	140 - 180	720 - 740

Note 备注:

The "*" in the model code express bonding wire types.
 型号代码中 "*" 表示可选键合线类型。

4. Typical Characteristics Graphs 典型特性曲线

a) Spectrum Distribution 光谱图 ($I_f = 150 \text{ mA}$, $T_j = 25 \text{ }^\circ\text{C}$)

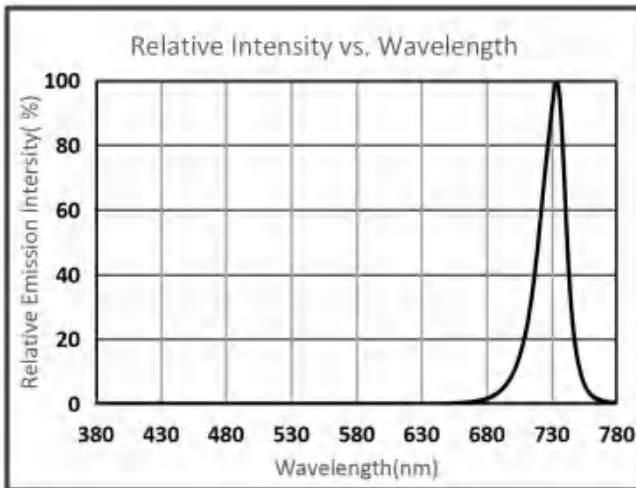

b) Temperature Characteristics 温度曲线

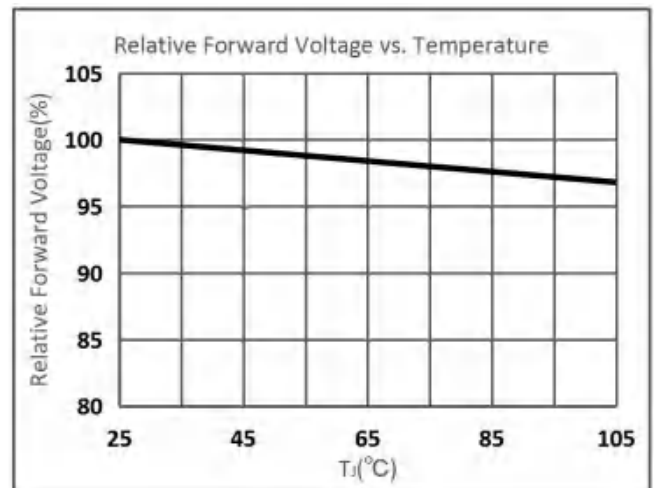
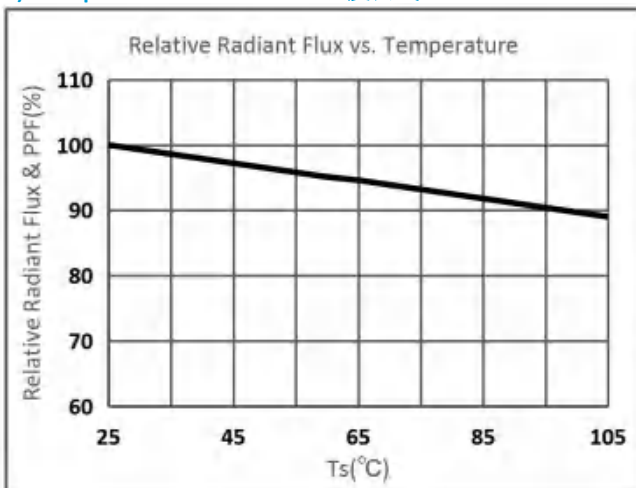

c) Forward Current Characteristics 电流曲线 ($T_j = 25 \text{ }^\circ\text{C}$)

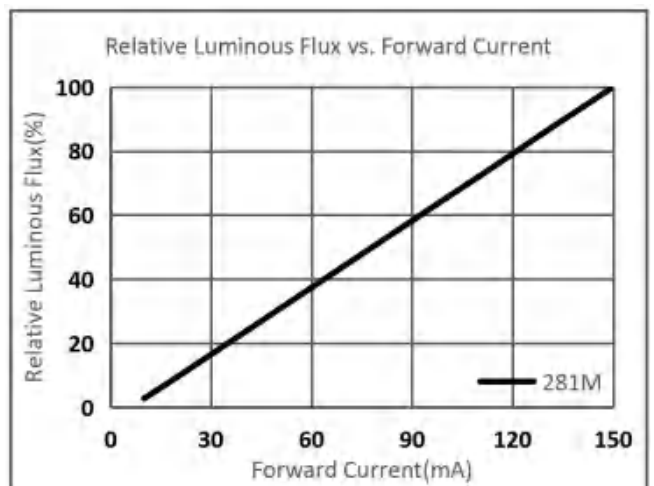
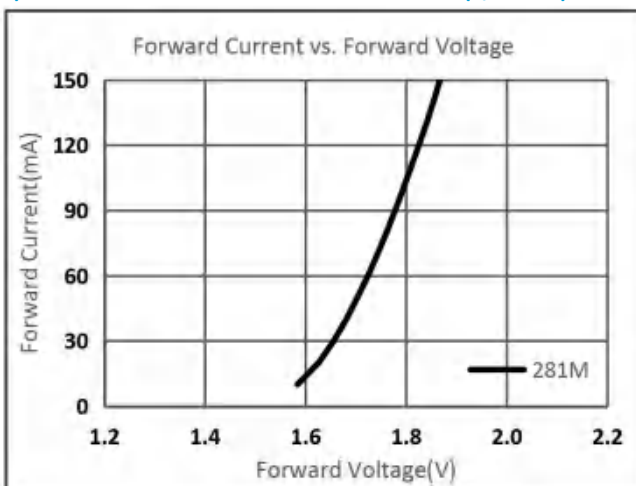

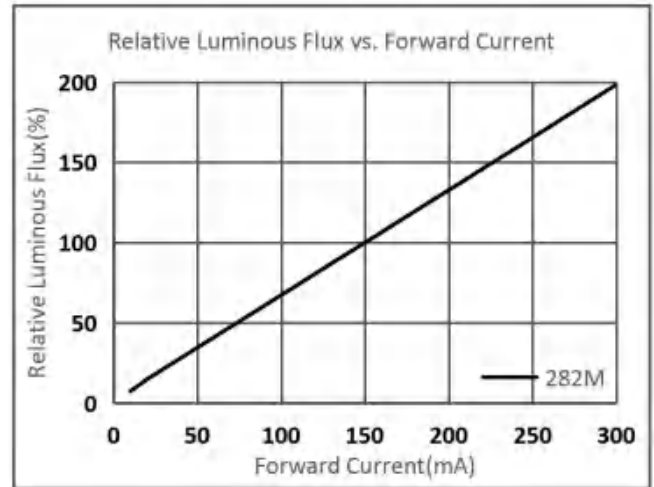
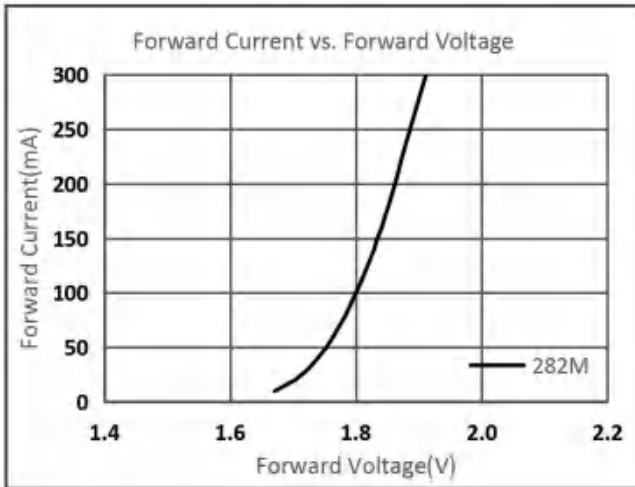

d) Derating Curve 电流下降曲线

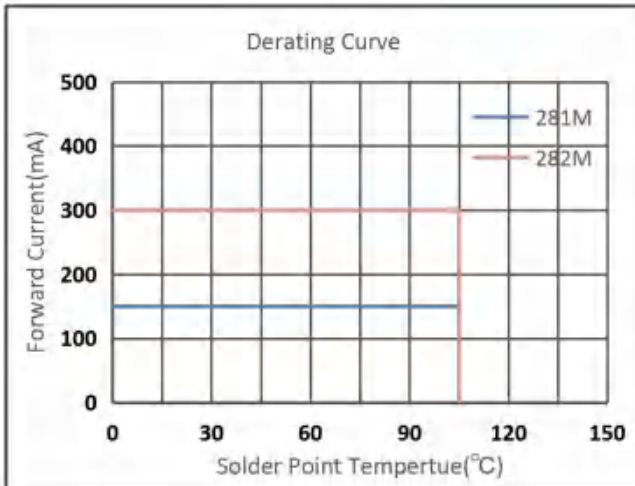

e) Beam Angle Characteristics 光束角 ($T_j = 25^\circ\text{C}$)

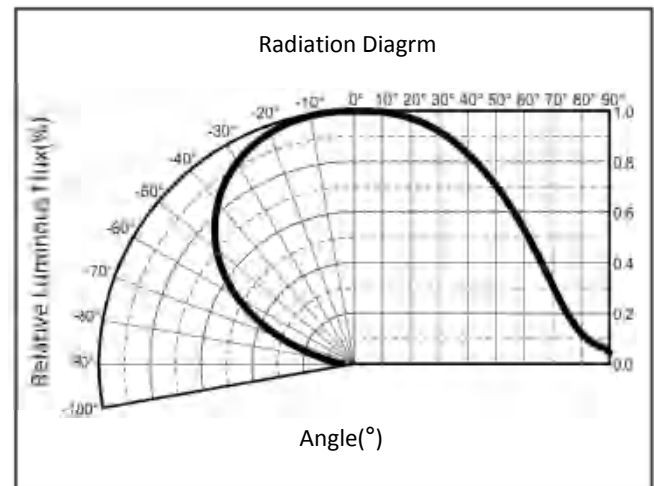

g) Typical Characteristics Data List 典型特性数据列表 (T_J = 25 °C)

 Table 1. List of typical characteristics data list for 281M series, T_J = 25 °C

表1: 281M系列典型特性数据列表

I _F (mA)	V _F (V)	Φ _v (lm)	Φ _e (mW)	Efficacy (lm/W)	WLD (nm)	WLP (nm)	PPF (μmol/s)	PPE (μmol/J)
20	1.698	0.0233	24.02	0.69	-	733.1	0.0069	0.20
40	1.769	0.0499	47.06	0.71	-	732.7	0.0157	0.22
60	1.822	0.0767	69.17	0.70	-	730.5	0.0252	0.23
80	1.868	0.1053	90.37	0.70	-	729.9	0.0350	0.23
90	1.889	0.1194	100.6	0.70	-	730.0	0.0402	0.24
100	1.910	0.1335	110.7	0.70	-	729.8	0.0453	0.24
120	1.948	0.1646	130.3	0.70	-	731.1	0.0565	0.24
130	1.967	0.1813	139.7	0.71	-	730.0	0.0617	0.24
140	1.984	0.1912	148.9	0.69	-	729.9	0.0665	0.24
150	2.001	0.2083	157.9	0.69	-	730.2	0.0719	0.24

 Table 1. List of typical characteristics data list for 282M series, T_J = 25 °C

表1: 282M系列典型特性数据列表

I _F (mA)	V _F (V)	Φ _v (lm)	Φ _e (mW)	Efficacy (lm/W)	WLD (nm)	WLP (nm)	PPF (μmol/s)	PPE (μmol/J)
20	1.784	0.018	19.21	0.50	-	730.9	0.004	0.11
40	1.827	0.037	39.02	0.52	-	731.5	0.009	0.12
60	1.858	0.056	59.03	0.50	-	732.1	0.013	0.12
80	1.883	0.076	78.86	0.52	-	733.1	0.018	0.12
100	1.904	0.092	98.58	0.49	-	733.6	0.022	0.12
120	1.923	0.107	118.34	0.47	-	733.6	0.026	0.11
150	1.949	0.134	147.48	0.47	-	734.5	0.032	0.11
200	1.989	0.176	195.36	0.44	-	735.9	0.042	0.11
250	2.002	0.199	239.40	0.41	-	738.2	0.048	0.10
300	2.050	0.229	286.32	0.37	-	739.2	0.057	0.10

5. Outline Drawing & Dimension 外形图与尺寸

(unit: mm)

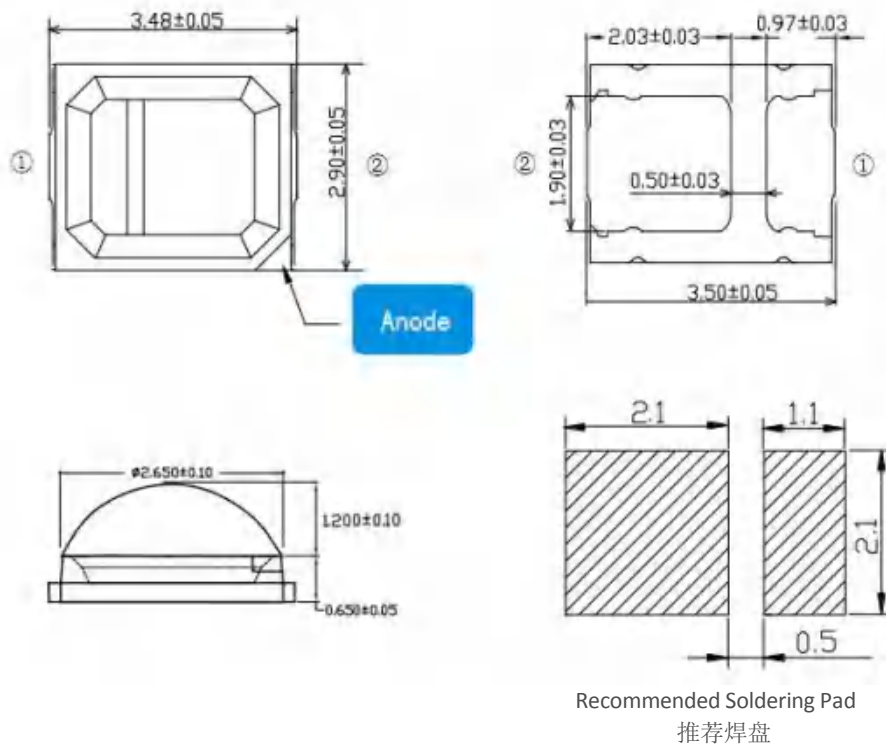
 Recommended Soldering Pad
 推荐焊盘

Notes 备注:

T_s point and measurement method:

T_s 点及测量方法:

- ① Measure one point at the cathode pad, if necessary remove PSR of PCB to reach T_s point.
在负极焊盘处测量一个点，如有必要，移除PCB的阻焊层以接触 T_s 点。
- ② All pads must be soldered to the PCB to dissipate heat properly, otherwise the LED can be damaged.
所有焊盘都必须焊接到印刷电路板上，以便正确散热，否则LED可能会损坏。

Precautions 注意事项:

- 1) Pressure on the LEDs will influence to the reliability of the LEDs. Precautions should be taken to avoid strong pressure on the LEDs. Do not put stress on the LEDs during heating.
LED上方压力会影响其可靠性。应采取预防措施，避免对LED施加过大的压力。在加热过程中，切勿对LED施加应力。
- 2) Re-soldering should not be done after the LEDs have been soldered. If re-soldering is unavoidable, LED's characteristics should be carefully checked before and after such repair.
LED焊接后不建议进行重新焊接。若必须进行重新焊接，则应在修复前后仔细检查LED的特性。
- 3) Do not stack assembled PCBs together. Since materials of LEDs is soft, abrasion between two PCB assembled with LED might cause catastrophic failure of the LEDs.
请勿将组装好的印刷电路板堆叠在一起。由于LED的材料较软，两个装有LED的PCB之间的磨擦可能会导致LED发生故障。

6. Reliability Test Items & Conditions 可靠性测试项目与条件

a) Test Items 测试项目

Test Item 测试项目	Test Condition 测试条件	Test Hour / Cycle 测试时间/循环	Sample No. 样本数
Room Temperature Life Test 常温老化	25 °C, DC = Maximum Forward Current	1000 h	22
High Temperature Life Test 高温老化	85 °C, DC = Maximum Forward Current	1000 h	22
High Temperature Humidity Life Test 高温高湿老化	85 °C, 85% RH, DC = Maximum Forward Current	1000 h	22
Low Temperature Life Test 低温老化	-40 °C, DC = Maximum Forward Current	1000 h	22
Powered Temperature Cycle Test 温度循环老化	-40 °C ~ 85 °C, each 10 min, On/Off 5 min, Temp. Change Time 20 min, DC = Maximum Forward Current	100 cycles	22
Thermal Shock 冷热冲击	-40 °C / 15 min ↔ 105 °C / 15 min	200 cycles	100
High Temperature Storage 高温储存	105 °C	1000 h	22
Low Temperature Storage 低温储存	-40 °C	1000 h	22

b) Criteria for Judging the Damage 失效判定标准

Test Item 测试项目	Symbol 符号	Test Condition (T _j = 25 °C) 测试条件	Limit 限制	
			Min. 下限	Max. 上限
Forward Voltage 正向电压	V _F	I _F = Sorting Current I _F = 分光电流	L.S.L. * 0.9	U.S.L. * 1.1
Radiant Flux 辐射通量	Φ _e	I _F = Sorting Current I _F = 分光电流	L.S.L. * 0.7	U.S.L. * 1.3

7. Soldering Condition 焊接条件

a) Reflow Conditions(Pb free) 回流焊条件（无铅）

Reflow frequency: 2 times max.

回流焊次数：最多2次

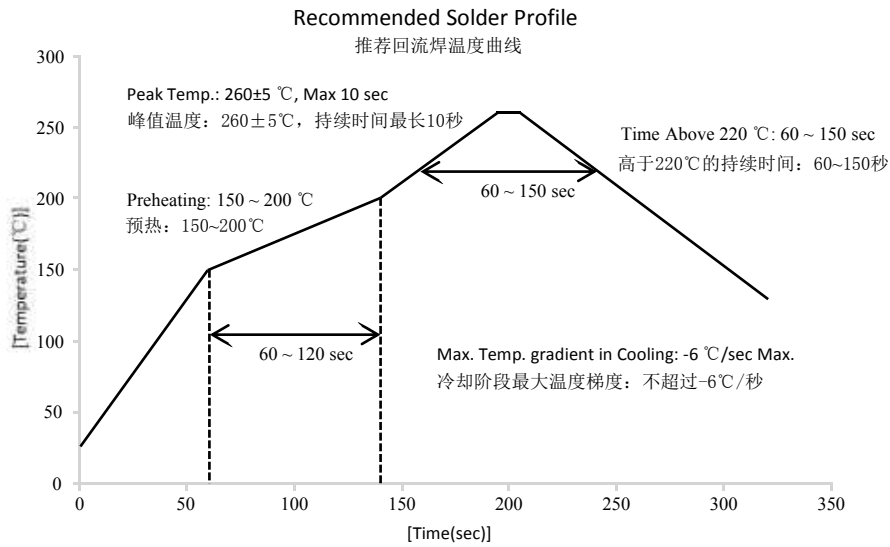

b) Manual Soldering Conditions 手动焊接条件

Not more than 5 seconds @ max. 300 °C, under soldering iron.

在最高300°C的条件下，使用烙铁时，不得超过5秒。

8. Tape & Reel 卷带

a) Taping Dimension 卷带尺寸

(unit: mm)

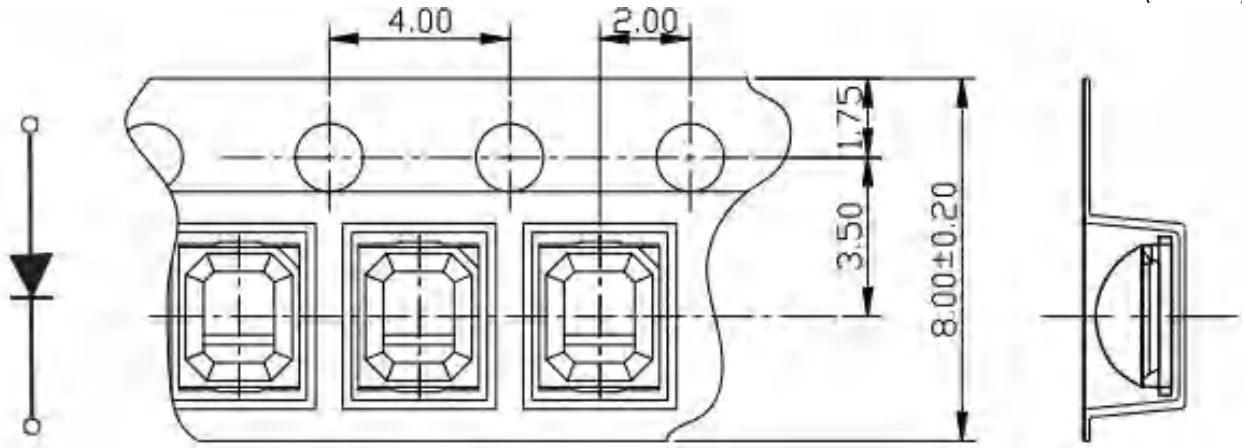

Taping Direction 编带方向 →

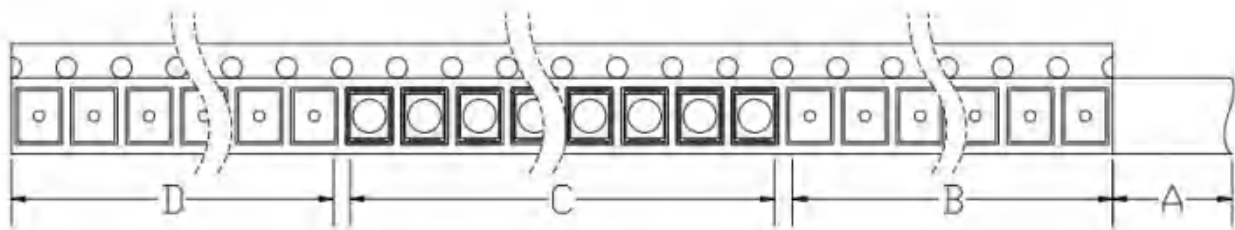

A: Top Cover Tape, 300 mm; B: Leader, Empty, 200 mm; C: 2000 or 4000 Lamps Loaded; D: Trailer, Empty, 200 mm.

b) Reel Dimension 卷轴尺寸
A: 7 inch diameter reel 7英寸直径卷轴

(unit: mm)

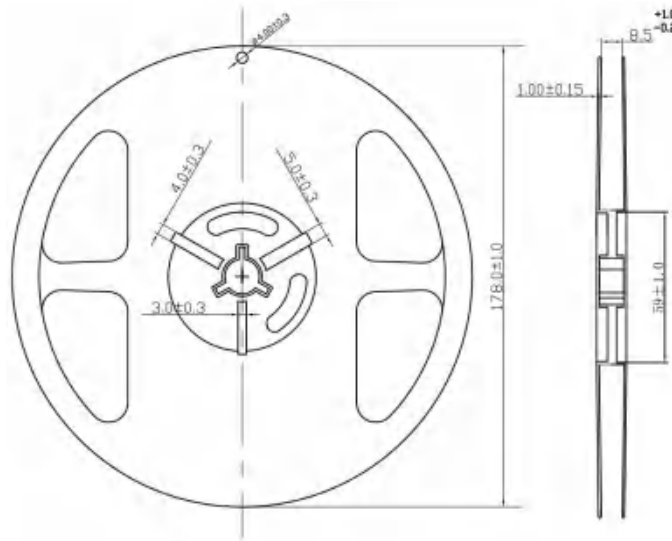
B: 13 inch diameter reel 13英寸直径卷轴

(unit: mm)

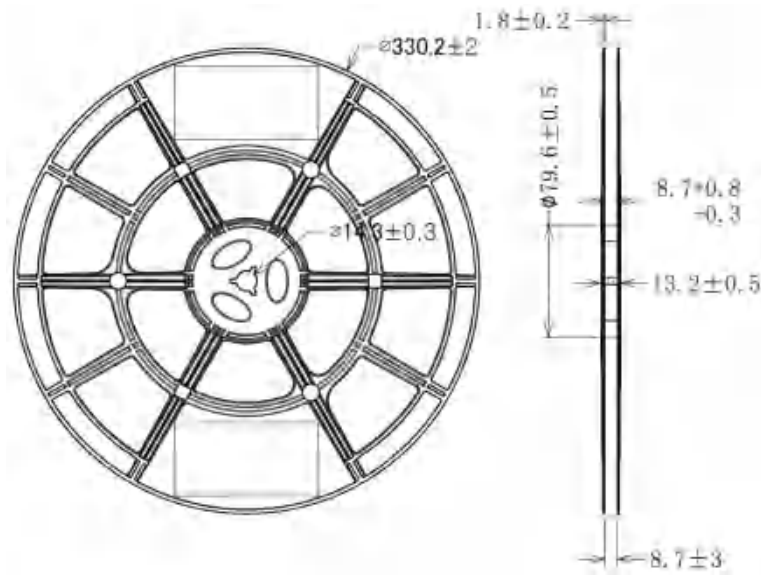
Notes 备注:

- 1) Quantity: The quantity/reel is 2,000 pcs in 7 inch diameter reel, 4,000 pcs in 13 inch diameter reel.
数量: 每卷数量7英寸直径卷轴2,000颗, 13英寸直径卷轴4,000颗。
- 2) Cumulative Tolerance: Cumulative tolerance / 10 pitches is ± 0.2 mm.
累积公差: 每10个孔距的累积公差为 ± 0.2 毫米。
- 3) Adhesion Strength of Cover Tape: Adhesion strength is 0.1 - 0.7 N when the cover tape is turned off from the carrier tape at 10° angle to the carrier tape
盖带的粘合强度: 当盖带与载带成10°角从载带上剥离时, 粘合强度为0.1-0.7N。
- 4) Packaging: P/N, Manufacturing data code no. and quantity are indicated on the aluminum packing bag.
包装: P/N、制造数据代码和数量显示在铝制包装袋上。

9. Label Structure 标签结构

a) Label Structure 标签结构



Note: Denoted bin code and product code above is only an example(see description on page 4 - 6)
 备注: 上述标签的BIN代码和产品代码仅为示例 (具体见第4-6页的说明)

b) Label Explanation 标签说明

Part No.: Product Code (产品型号)

IF: Testing Current (测试电流)

VF: Forward Voltage Range (电压范围)

Flux: Radiant Flux Range (辐射通量范围)

WLD(WLP): Wavelength Range (波长范围)

Date: Packing Date (包装日期)

Bin Code: Rank (参数范围代码)

C/N: Internal Identification Code (内部识别料号)

Remark: Special Remark (特别备注)

QTY: Quantity (数量)

Lot No.: Production Batch Number (批号)

10. Packing Structure 包装结构

a) Packing Process (The quantity of PKG on the Reel to be Max 2,000 or 4,000 pcs) 包装过程 (每卷最大包装量2,000或4,000pcs)

Reel 卷轴

Progressive Direction 前进方向 →

Label 标签

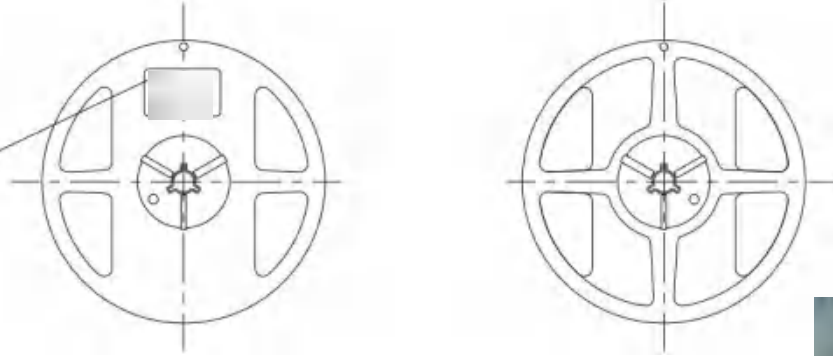

Aluminum Vinyl Packing Bag 铝箔袋包装

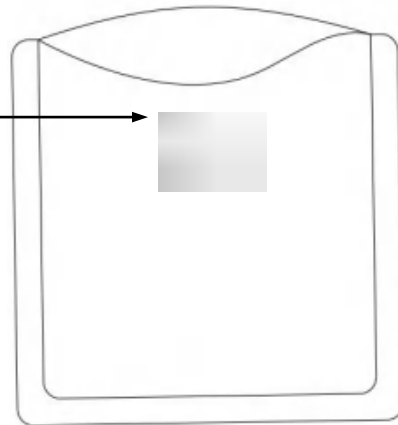

Outer Box 外箱包装

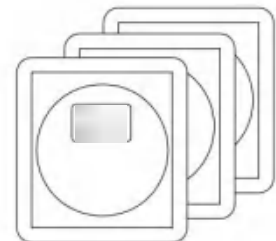
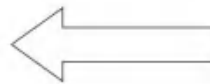

b) Aluminum Vinyl Packing Bag 铝箔袋包装



11. Precautions in Handling & Use 搬运和使用注意事项

- 1) For over-current protection, users are recommended to apply resistors connected in series with the LEDs to mitigate sudden change of the forward current caused by shift of forward voltage.
对于过电流保护，建议用户使用与LED串联的电阻器，以减轻正向电压偏移引起的正向电流的突然变化。
- 2) This device should not be used in any type of fluid such as water, oil, organic solvent, etc. When cleaning is required, IPA is recommended as the cleaning agent. Some solvent-based cleaning agent may damage the silicone resins used in the device.
该设备不应用于任何类型的流体，如水、油、有机溶剂等。当需要清洁时，建议使用IPA作为清洁剂。一些溶剂型清洁剂可能会损坏设备中使用的硅树脂。
- 3) When the device is in operation, the forward current should be carefully determined considering the maximum ambient temperature and corresponding junction temperature.
当设备运行时，应仔细考虑最高环境温度和相应的结温来确定正向电流。
- 4) LEDs must be stored in a clean environment. If the LEDs are to be stored for three months or more after being shipped from Ledestar, they should be packed with a nitrogen-filled container (shelf life of sealed bags is 12 months at temperature 0~40 °C, 0~90% RH).
LED必须存放在清洁的环境中。如果LED从立德达发货后要储存三个月或更长时间，则应使用充氮容器包装（密封袋在0~40°C、0~90%RH的温度下的保质期为12个月）。
- 5) After storage bag is opened, device subjected to soldering, solder reflow, or other high temperature processes must be:
 - a. Mounted within 672 hours (28 days) at an assembly line with a condition of no more than 30 °C / 60% RH, or
 - b. Mounted within 672 hours (28 days) at an assembly line with a condition of no more than 30 °C / 60% RH, or
 - c. Stored at <10% RH.打开储物袋后，经过焊接、回流焊或其他高温处理的设备必须：
 - a. 在672小时（28天）内安装在温度不超过30°C/60%相对湿度的装配线上，或
 - b. 在24小时（1天）内安装在温度超过30°C/70%RH的装配线上，或
 - c. 在相对湿度<10%的条件下储存。
- 6) Repack unused devices with anti-moisture packing, fold to close any opening and then store in a dry place.
用防潮包装重新包装未使用的LED，折叠以封闭任何开口，然后存放在干燥的地方。
- 7) Devices require baking before mounting, if humidity card reading is >60% at 23 ± 5 °C, Devices must be baked for 10~24 hours at 70 ± 5 °C, if baking is required.
如果湿度卡读数在23 ± 5°C下>60%，则设备在安装前需要烘烤，如果需要烘烤，设备必须在70 ± 5°C下烘烤10~24小时。
- 8) The LEDs are sensitive to the static electricity and surge current. It is recommended to use a wrist band or anti-electrostatic glove when handling the LEDs. If voltage exceeding the absolute maximum rating is applied to LEDs, it may cause damage or even destruction to LED devices. Damaged LEDs may show some unusual characteristics such as increase in leakage current, lowered turn-on voltage, or abnormal lighting of LEDs at low current.
LED对静电和浪涌电流很敏感。处理LED时，建议使用腕带或防静电手套。如果向LED施加超过绝对最大额定值的电压，则可能会对LED器件造成损坏甚至破坏。损坏的LED可能会显示出一些异常特征，如漏电流增加、开启电压降低或LED在低电流下异常点亮。
- 9) VOCs (Volatile Organic Compounds) can be generated from adhesives, flux, hardener or organic additives used in luminaires (fixtures). Transparent LED silicone encapsulant is permeable to those chemicals and they may lead to a discoloration of encapsulant when they exposed to heat or light. This phenomenon can cause a significant loss of light emitted from the luminaires. In order to prevent these problems, we recommend users to know the physical properties of materials used in luminaires and they must be carefully selected.
挥发性有机化合物（VOC）可由灯具（固定装置）中使用的粘合剂、助焊剂、硬化剂或有机添加剂产生。透明LED硅胶封装材料可渗透这些化学物质，当它们暴露在高温或光照下时，可能会导致封装材料变色。这种现象会导致灯具发出的光大幅损失。为了防止这些问题，我们建议用户了解灯具中使用的材料的物理性能，必须仔细选择。
- 10) Risk of sulfurization (or tarnishing) The LED from Ledestar uses a silver-plated lead frame and its surface color may change to black (or dark colored) when it is exposed to sulfur (S), chlorine (Cl) or other halogen compound. Sulfurization of lead frame may cause intensity degradation, change of chromaticity coordinates and, in extreme cases, open circuit. It requires caution. Due to possible sulfurization of lead frame, LED should not be used and stored together with oxidizing substances made of materials such as rubber, plain paper, lead solder cream, etc.
硫化（或变色）风险，立德达的LED使用镀银支架，当暴露在硫（S）、氯（Cl）或其他卤素化合物中时，其表面颜色可能会变为黑色（或深色）。支架的硫化可能会导致亮度下降、色度坐标变化，在极端情况下还会导致断路。这需要谨慎。由于支架可能硫化，LED不应与橡胶、普通纸、铅焊膏等材料制成的氧化物质一起使用和储存。

